

*This amazing advancement in Line-Blinding Technology can save you hundreds of thousands, if not millions of dollars per year in **DRASTICALLY REDUCED MAINTENANCE COSTS**, far less downtime and improved reliability and safety.*

ABSOLUTELY INCREDIBLE...

A SINGLE OPERATOR CAN NOW RAPIDLY, PROPERLY AND SAFELY BLANK-OFF ANY SIZE AND NUMBER OF PROCESS GAS OR LIQUID LINES TO ANY FURNACE, BOILER, REACTOR, TANK OR FLARE STACK IN LESS THAN 2 MINUTES.

Since its inception 20 years ago, the **ONIS Rapid-Line-Blinding System** has been setting a new world standard (first in Europe and now in North America) for rapid, safe and dependable blanking off of key process equipment for some of the most respected names in the Petrochemical Industry.

BAYER • BASF • DOW • DUPONT • EXXON • HUNTSMAN • ROHM & HAAS • SHELL

Most petrochemical plants in North America still employ primitive methods and equipment to accomplish this crucial task which is one of the most risky and time-consuming maintenance procedures in the operation of any plant.

STATE-OF-THE-ART YESTERDAY



Is this your plant? Crews of maintenance personnel wrestling with flange alignment tools, clumsy pancake & spectacle-blinds and gaskets. This procedure is hit-and-miss and can take 4 hours or more to successfully swing a single blank. Expensive cranes and scaffolding are often required for elevated locations.

STATE-OF-THE-ART TODAY

ONIS RAPID LINE-BLINDING SYSTEM

SPREADS THE PIPE APPROXIMATELY 1/8" APART.

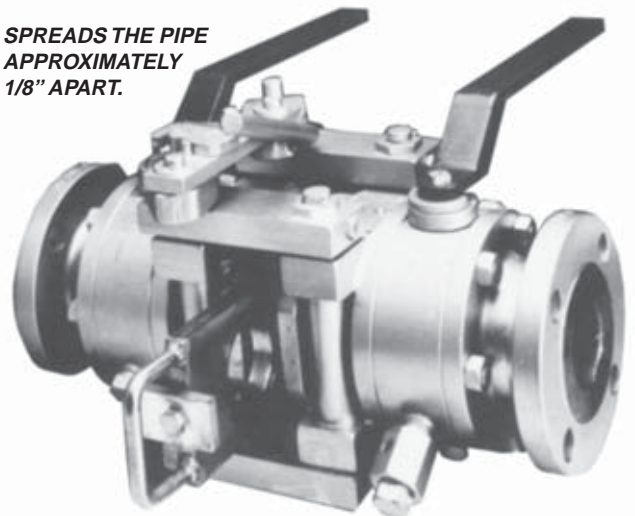

MANUAL SHOWN; AUTOMATED ALSO AVAILABLE

One person can do the job with the ease of operating a high-performance valve or automatically by pushing a button (either way usually takes less than 2 minutes on any line size 1/2" to 48"). No maintenance personnel, special tools, cranes or scaffolding are required for operation. **TYPICAL SIX-MONTH-PAYBACK.**

ONIS RAPID LINE-BLINDING SYSTEMS
CARRY CANADIAN REGISTRATION NUMBERS & A FIRE-TEST CERTIFICATE

ONIS LINE-BLINDING SYSTEMS are stocked in Sarnia
by **Great Lakes Industrial Controls.**

For a physical demonstration of this unique product contact...

GREAT LAKES INDUSTRIAL CONTROLS

3560 Pine Grove Ave. - Unit #352
Port Huron, Michigan 48060

Phone: 1-800-546-0705
Fax: 1-866-755-8658

1387 Confederation Street
Sarnia, Ontario N7S 5P1

OVER 

*This amazing advancement in Line-Blinding Technology can save you hundreds of thousands, if not millions of dollars per year in **DRASTICALLY REDUCED MAINTENANCE COSTS**, far less downtime and improved reliability and safety.*

FINALLY A PROVEN RAPID-LINE-BLINDING SYSTEM THAT ALLOWS FAST AND EASY ACCESS FOR THE INSPECTION OF TANKS AND VESSELS

Since its inception 20 years ago, the **ONIS Rapid-Line-Blinding System** has been setting a new world standard (first in Europe and now in North America) for rapid, safe and dependable blanking off of key process equipment for some of the most respected names in the Petrochemical Industry.

BAYER • BASF • DOW • DUPONT • EXXON • HUNTSMAN • ROHM & HAAS • SHELL

Most petrochemical plants in North America still employ primitive methods and equipment to accomplish this crucial task which is one of the most risky and time-consuming maintenance procedures in the operation of any plant.

STATE-OF-THE-ART YESTERDAY

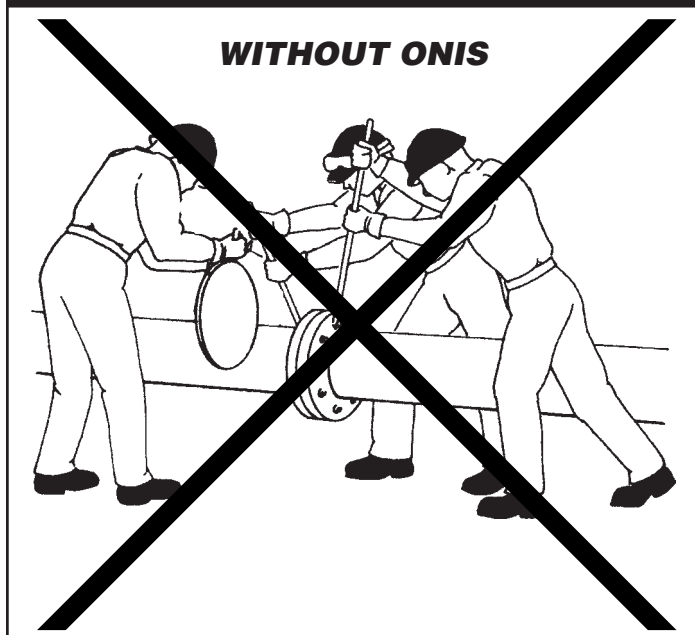

Is this your plant? Crews of maintenance personnel wrestling with flange alignment tools, clumsy pancake & spectacle-blinds and gaskets. This procedure is hit-and-miss and can take 4 hours or more to successfully swing a single blank. Expensive cranes and scaffolding are often required for elevated locations.

STATE-OF-THE-ART TODAY

ONIS RAPID LINE-BLINDING SYSTEM

*SPREADS THE PIPE
APPROXIMATELY
1/8" APART.*

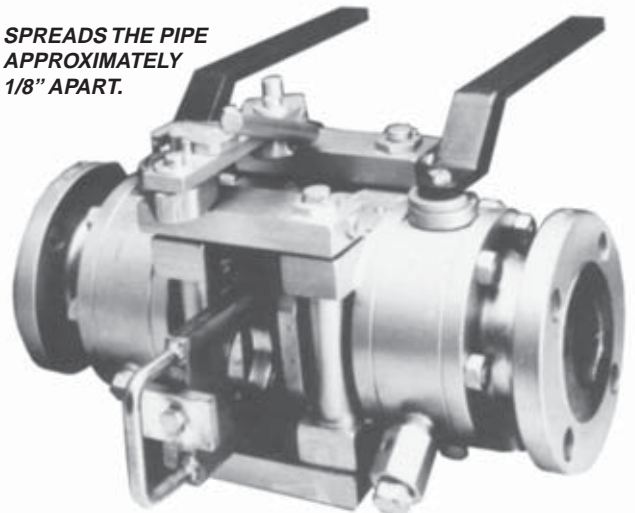

MANUAL SHOWN; AUTOMATED ALSO AVAILABLE

*One person can do the job with the ease of operating a high-performance valve or automatically by pushing a button (either way usually takes less than 2 minutes on any line size 1/2" to 48"). No maintenance personnel, special tools, cranes or scaffolding are required for operation. **TYPICAL SIX-MONTH-PAYBACK.***

**ONIS RAPID LINE-BLINDING SYSTEMS
CARRY CANADIAN REGISTRATION NUMBERS & A FIRE-TEST CERTIFICATE**

ONIS LINE-BLINDING SYSTEMS are stocked in Sarnia
by **Great Lakes Industrial Controls.**

For a physical demonstration of this unique product contact...

GREAT LAKES INDUSTRIAL CONTROLS

3560 Pine Grove Ave. - Unit #352
Port Huron, Michigan 48060

Phone: 1-800-546-0705
Fax: 1-866-755-8658

1387 Confederation Street
Sarnia, Ontario N7S 5P1

OVER →

ONIS RAPID LINE-BLINDING SYSTEM

How It Works

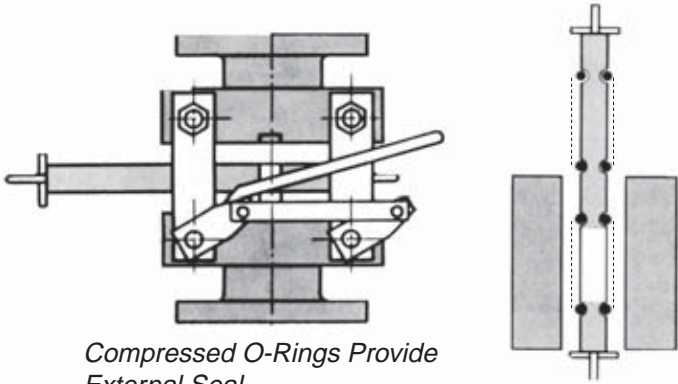

Compressed O-Rings Provide External Seal

The ONIS device utilizes two flanged or welded body halves which are connected by a set of eccentric bolts and linkage plates. This arrangement creates tremendous mechanical advantage such that one person can spread a 12" section of pipe with a lever.

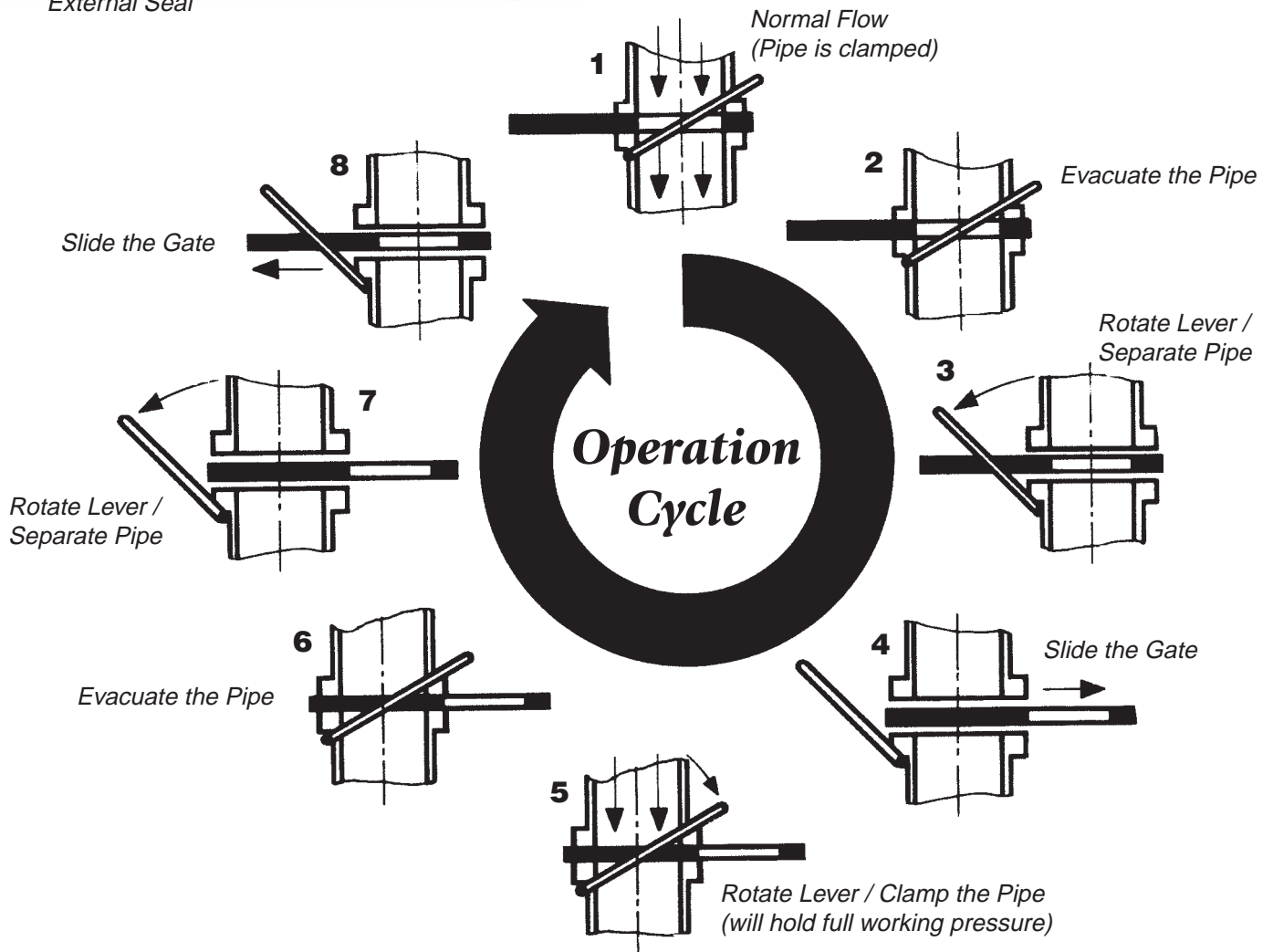

USERS LIST

AIR PRODUCTS
 ATOCHEM
 BASF
 BAYER
 BF GOODRICH
 CELANESE
 CERTAINTEED
 CHEVRON

CIBA GEIGY
 CROWN
 OCCIDENTAL
 DOW
 DUPONT
 DSM
 EXXON
 FINA

FMC
 GOODYEAR
 HUNTSMAN
 LA PIGMENTS
 ROHM & HAAS
 MONSANTO
 PEMEX
 PHILLIPS

SHELL
 STAR ENTERPRISE
 UNION CARBIDE
 UOP
 VISTA
 WESTLAKE POLY
 WESTLAKE PVC
 ZEON

ONIS LINE-BLINDING SYSTEMS are stocked in Sarnia by Great Lakes Industrial Controls.

For a physical demonstration of this unique product contact...

GREAT LAKES INDUSTRIAL CONTROLS

3560 Pine Grove Ave. - Unit #352
 Port Huron, Michigan 48060

Phone: 1-800-546-0705
 Fax: 1-866-755-8658

1387 Confederation Street
 Sarnia, Ontario N7S 5P1

OVER →